

Dear CW-Friend,

Many thanks for choosing our product. This key was developed by our company and is entirely produced at our local manufacturing base. We only used high quality primary materials and ensured accurate assembling and testing.

Please find below some adjustment details for the key.

The pretension calibration of the lever is possible within a range of 5 to 45 g for each side.
The keys are delivered with a pretension of approx. 12 g. Pretension and upstroke can be adjusted to the individual needs of the operator. To adjust please unloose the locking screw on the bottom side by using the enclosed hex-wrench. Now pretension and upstroke can be changed by adjusting the slotted side screw bits.

Please note – Do not entirely unloose the locking screw while adjusting pretension and upstroke. The adjustment can be done more precisely by doing so. Following the adjustment please tighten the locking screws – do not use force.

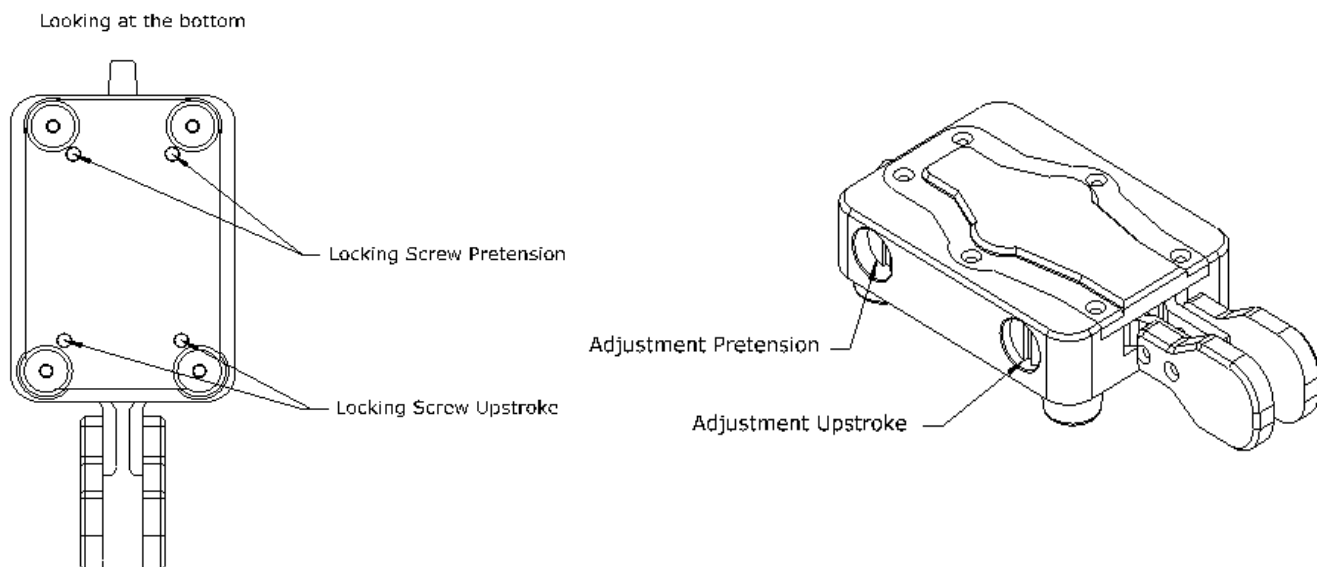

To ensure safe fit of the lever in the optional magnet base 206119 the slotted cylinder screws in the rubber feet can be adjusted to the magnets of the magnet base by screwing them in or out minimally. The key needs to be firmly attached to the magnet base to ensure safe and reproducible operation.

Please note – The key only fits in one direction into the magnet base. If required please rotate by 180 degrees.

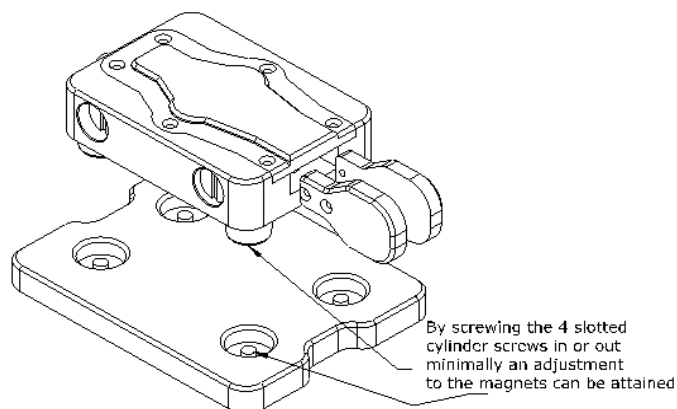

We wish many nice and failure-free QSO's with your new key.
We would be delighted if you would be satisfied with the key and recommend us.

Vy 73 de Markus Baseler – DL6YYM
Inh. BaMaTech – Feinmechanik